

Top One Tech LIMITED

10.1" All-In-One PC

(PCAP touch screen and water-proof Type)

Model: TOT101UPC006

Part number:TTA101L1C001



Top One Tech's 10.1" water-proof IP65 open frame LCD touch PC have a long-lasting product cycle because the enclosure is controlled by Top One Tech's specifications. Future panel improvements are therefore possible without external changes. The TOT101UPC006 integrate with the Top One Tech's PCAP technology touchscreen.

Features

- Edge-to-edge glass IP65 rated
- 10-finger multitouch touch screen Panel
- RK3566/2G/16G/
- 2GB RAM
- 16GB SSD included
- 2Bit and 64Bit support, Android
- Integrated Wi-Fi, 1×LAN
- VESA 75 /100 bracket for mounting, metal stand included
- Customization available upon reques

Specification

Product name	10.1" PCAP Touch PC		
Modle numer	TOT101UPC006		
Anti-glare LCD Panel		PC System	
IP rated front panel	IP65	CPU	RK3566
Screen diagonal (Inch):	10.1 "	Memory	2GB
Display active screen size:	217.0*316.0(mm)	Storage	16GB
Aspect ratio:	16:10	USB Port	1*USB 2.0, 2*USB 3.0
Physical resolution:	1280*800	RS232	1*RS232 or 485
Colours displayed:	16.7M	I/O	RJ45
Brightness (cd/m2):	350	GPIO	Support 3 chanel GPIO
Contrast:	800:1	Wifi/Buletooth	Support
Typical reaction time Tr/ Tf :	10/15 (ms)	System	Android 11
Visual Angle horizontal/vertical :	170/170	Touch Panel	

Backlight / Backlight Lifetime (hours):	LED / 30,000	Touch Technology	Projected Capacitive 10-point Multitouch
Operation / Mechanical		Touch Connector	I2C
Operating Temperature	-10 ~ +65 (°C)	Touch Panel Drivers	Windows; Linux; Mac; Android
Humidity Range (RH)	10%-90%	Touch Life (Contacts)	Unlimited
Net weight (kg)	2	Surface Hardness	7H
Housing material	Aluminium	Power	
Housing (cm) LxW	265*185*39	Power Indicator	Green LED
Mounting	VESA 75/100	Power Supply	100-240V ACDC active switch- ing; 12V DC-Out
/		Working Power (V)	12
/		Power Consumption (W)	11
/		Stand-By Consumption (W)	<1

NOTE:The display SPEC. will change follow the relevant LCD panel brand and model

Mechanical Dimensions

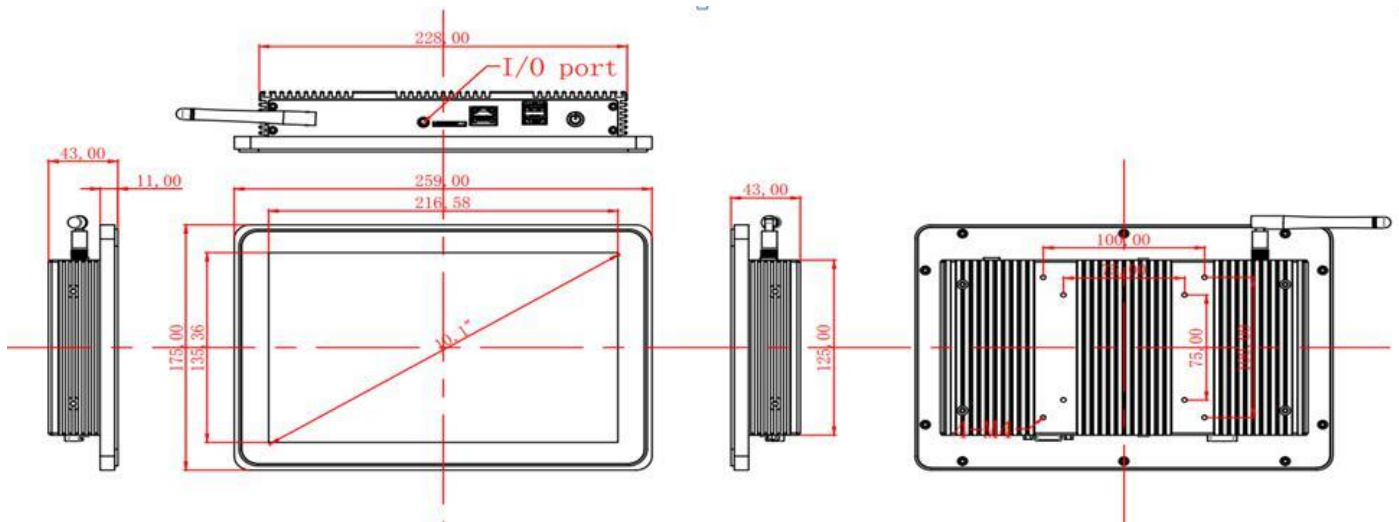

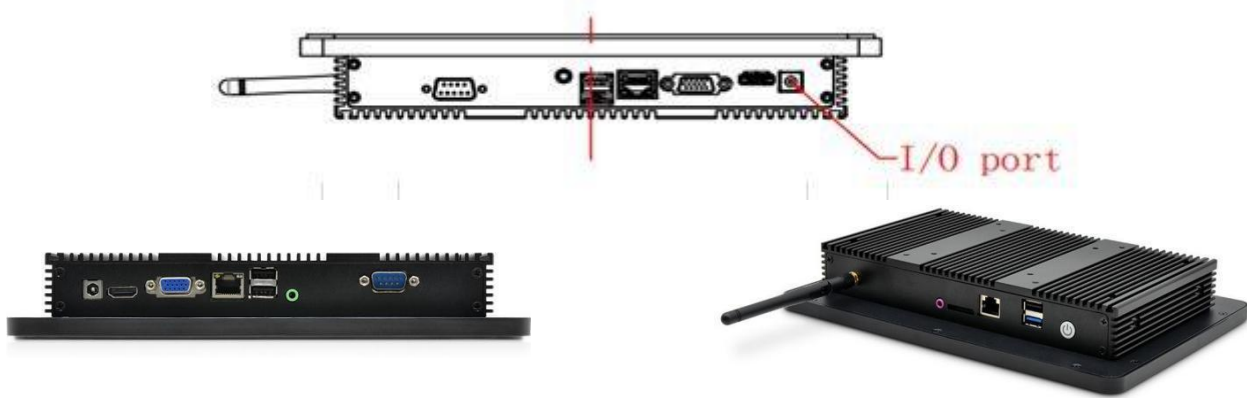

Accessories

Power Cable: A North American power cable or an European power cable is included according to the end user's area.

L-Power Supply Brick: A power supply brick is included.(optional by different size).

Touch/Video/DVI Cables: Detachable serial or USB touch cable, video cable and DVI cable are included

M-brackets: Four standard L-brackets are included(optional by different size).

Typical Application

- Information Kiosk
- Banking ATM
- Casino Gaming machine
- Industrial Control
- Transportation
- Education and Training

How to contact us

TOP ONE TECH LIMITED

Mobile Phone : (+86)13631610695

Tel: 0086-0755-21070641

Whatsapp/Wechat :+8613631610695

Email : sales@toponetech.cn

Skype : elsieyu-sz@hotmail.com

Office in China : Room1517, Taiyangneng Guigu Building Zhongxing Xiaoqu,Yunfeng Road No.3 Gaofeng shequ, Longhua District, Shenzhen, China

Facilities in China : No. 2,Guihua Jiayi Industrial district,Guanlan, Longhua,Shenzhen, China 518110