

## **Top One Tech LIMITED (HK)**

**22" LED Open Frame PCAP Multi-Touch Monitor**

**(PCAP and Zero-bezel Type)**

**Model: TOT220UCA001**

**Part number:TOT220K1C002**



Top One Tech's 22" open frame LED touch monitors have a long-lasting product cycle because the enclosure is controlled by Top One Tech's specifications. Future panel improvements are therefore possible without external changes. The TOT220UCA001 integrate with the Top One Tech's PCAP technology touchscreen.

## Features

- Fully Supports Aristocrat Viridian WS, Gen7, Upright Aristocrat Vii Slant, Aristocrat Viridian Hybird, Upright
- 1680x1050 Resoultion 16.7M Colors LCD Panel With LED Backlight
- HDMI + DVI + VGA Input Video Source
- DC-24V Input Voltage
- P-CAP 10 Points(Max) Touchscreen With RS232 Interface
- TouchScreen Supports Upgrade Firmware Via RS232 and USB Interface
- Certification CE,FCC,ROHS,UL,KCC etc.

## Specification

Complete Machine		
Model No.	TOT220UCA001	
Series	OT	
Display Type	16:10 Ratio 22" TFT-LCD	
Active Area	475.7*298(mm)	
Monitor Dimensions (W*H*D)	496.7*323*63(mm)	
Suggested Resolution	1680*1050 @ 60Hz	
Support Colors	16.7M	
Brightness	Pure LCD Panel	250cd/m2
	With Touch Monitor	212cd/m2
Response Time	1.3ms	
Viewing Angle	Horizontal(left/right)	85°/85°
	Vertical(up/down)	80°/80°
Contrast Ratio	1000:1(Typ.)/700:1(Min.)	
Video Input	VGA/DVI/HDMI	
Frequency (H/V)	37.9~100KHz / 60~77Hz	
Power Supply	Type: External brick Display voltage: DC 12V±5% Input (line) voltage: 100-240 VAC, 50-60 Hz	
Environment	Operating Temp.	0~50°C
	Storage Temp.	-20~60°C

<b>MTBF</b>	≥30,000 Hours	
<b>LED Back Light Life (Typ.)</b>	≥30,000 Hours	
<b>Weight ( N.W/G.W)</b>	24Kg (2pcs in one package)	
<b>Package dimensions</b>	685*230*480mm(2pcs in one package)	
<b>Power Consumption</b>	≤17W	
<b>Mount Interface</b>	1.VESA100mm 2.Mount bracket, horizontal or vertical mount	
<b>OSD Control</b>	Buttons	AUTO, +,POWER,-,MENU
	Function	Brightness, Contrast Ratio, Auto-adjust, Phase, Clock, H/V Location, Languages, Function, Reset
<b>Agency approvals</b>	CCC, UL, FCC, CE, CB, RoHS	
<b>Regular Warranty</b>	1 year	

## Touch Screen

<b>Touch Type</b>	22" Capacitive touch screens
<b>Touch input</b>	USB
<b>Response Time</b>	≤1.3ms
<b>Hardness</b>	6H
<b>Light Transmittance</b>	≥85%
<b>Support System</b>	XP, WIN7, WIN8, WIN10, Linux, Android
<b>Active Area</b>	475.7*298(mm)
<b>Thickness</b>	11±0.5(mm)
<b>Touch Test</b>	≥50,000,000 times
<b>Input Voltage</b>	DC 5V±5%

**NOTE: The display SPEC. will change follow the relevant LCD panel brand and model**

## Mechanical Dimensions

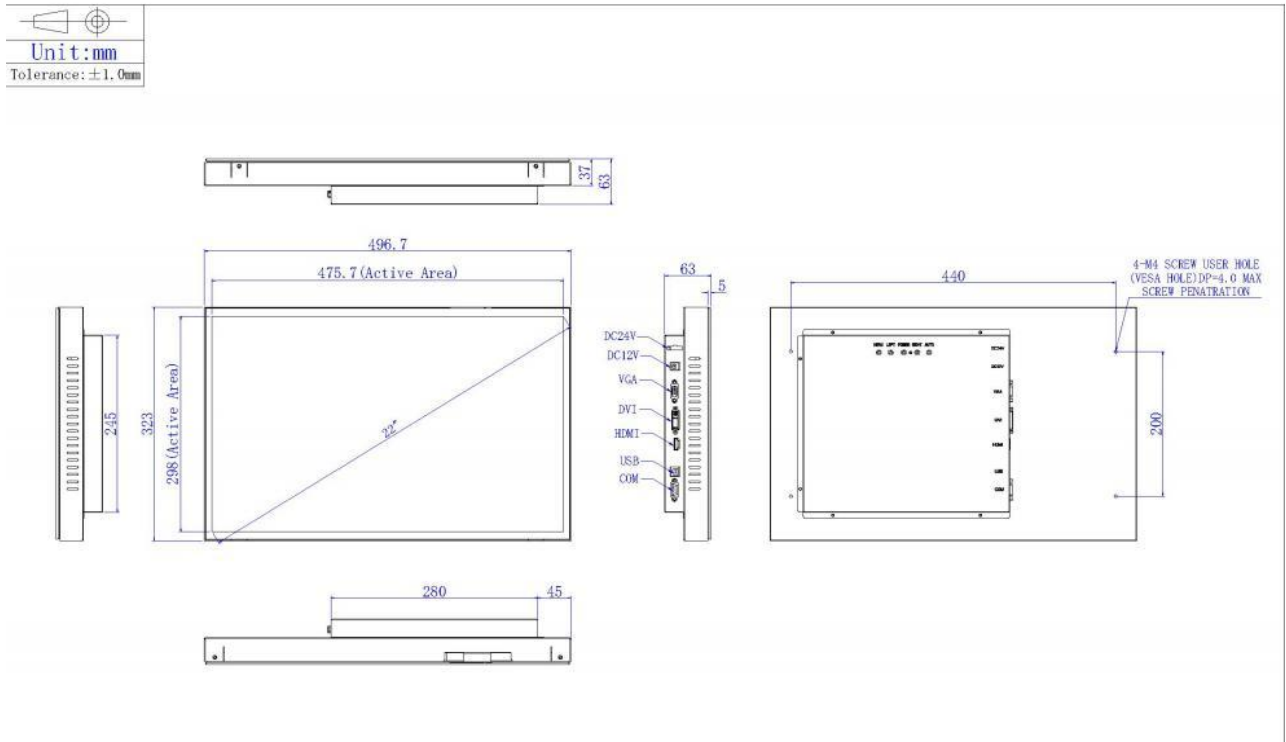

## Accessories

**Power Cable:** A North American power cable or an European power cable is included according to the end user's area.

**Power Supply Brick:** A power supply brick is included.

**Touch/Video/DVI Cables:** Detachable serial or USB touch cable, video cable and DVI cable are included

**L-brackets:** Four standard L-brackets are included. (optional based on size)

## Typical Application

- Information Kiosk
- Banking ATM
- Casino Gaming machine
- Industrial Control
- Transportation
- Education and Training

---

## How to contact us

TOP ONE TECH LIMITED

Mobile Phone : (+86)13631610695

Tel: 0086-0755-21070641

Whatsapp/Wechat :+8613631610695

Email : sales@toponetech.cn

Skype : elsieyu-sz@hotmail.com

Office in China : Room 2106, Building A, Zhiyun ONE Industrial Park, No. 13 Huaxing Road, Dalang Street, Longhua District, Shenzhen,China

Facilities in China : No. 2,Guihua Jiayi Industrial district,Guanlan, Longhua,Shenzhen, China 518109